

# HPC – HIGH PERFORMANCE COUNTING

## B03 Desktop Counting Machine

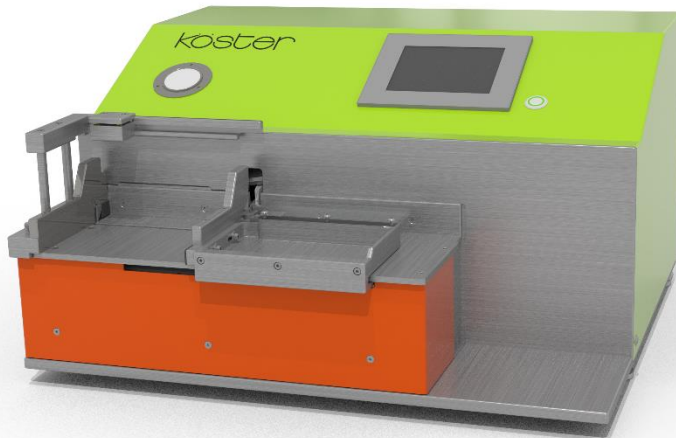

**köster**  
Maschinen- und Werkzeugbau

## Featuring:

### State of the art HPC Disc Counting Machine

Desktop HPC single head counting machine to count smallest format cut sizes as tax stamps, very sensitive products as post stamps and banknotes bundles:

- High speed - up to 200 sheets / second
- High efficiency - No compressed air required
- High accuracy - 99%
- High flexibility - GSM range 35 – 150
- High durability - Lowest maintenance costs

### State of the art HPC Disc Counting Technology

Counting direction from right to left grants:

- Accurate and fast product insert
- Easy handling for the operator

Corner counting position assures:

- No damages to the sheet corner
- No folding to the sheet corner
- No marks to the sheet corner
- Sheet to sheet misalignment within high tolerances can be processed
- Up and down corner curl within high tolerances can be processed

All kinds of substrates used in the global security printing industry can be damage-free counted on highest speed and highest accuracy:

- Cotton based substrates
- Coated substrates
- Hybrid substrates
- Laminated substrates

The low impact disc design allows the operator to avoid critical security zones on the substrates as security threads, holographic, applications, codes, intaglio printing, etc.

### State of the art HPC Disc Segment Recognition System

The built-in disc segment counting position recognition system assures that the disc stops accurate depending on the different counting operations definitely to avoid miscounting or mismatching due to non counted but already separated next sheet.

[www.koester-gmbh.com](http://www.koester-gmbh.com)

## Featuring:

### State of the Art HPC PLC Control

Integrated various range of counting operations and equipment functions:

- **Security Counting**, results are compared with presetted value, on mismatch the product is not automatically released.
- **Layers batching**, a preselected amount of sheets can be easily batched to a layer. The counting disc is used as separation to provide the operator a gap for easy layer unloading.
- **Separation knife**, increasing the gap visibility for the operator during the bundle amount checking of for example 100 notes bundles in 1000 notes stacks. Not compatible for tax stamps counting.
- **USB firmware or program update**, updates of firmware or program version are very easily performed using an USB memory stick.

### State of the Art HPC Machine Design

- Maintenance access is granted from top of the machine by opening the machine shell, all supplied components are high class products from global manufacturers, mostly available ex stock.
- The non-sophisticated machine design assures easy to handle maintenance, lowest grade and costs as well as highest production availability.
- The table is guided on hardened shafts, the precision-ground drive shaft is mounted in generously dimensioned ball bearings. The robust and precise structure in steel and aluminium including lowest production tolerances results to the high performance machine capability.

### Available Options:

- Separation knife to increase gap visibility for bundle amount checking within a product stack.
- Warranty extension 24 months except wear parts
- EPSON® Label printer



# Impressions:

## Machine and products

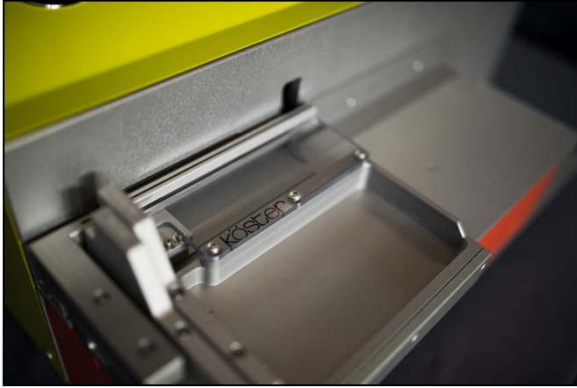

www.koester-gmbh.com

## Technical Specifications

<b>Dimensions</b>						
	L	W	H			
Over all (mm):	630	585	345			
Table (mm):		160				
<b>Machine weight</b>						
Machine weight (kg.):	65					
<b>Working height</b>						
Working height (mm):	Depending to used desk height					
<b>Supplies</b>						
Electrical connection:	Single phase 240 VAC ~50Hz / IEC C14 socket plug & play					
Compressed air:	Not required					
<b>Format sizes</b>						
	L	W	H			
Minimum layer height (mm):			5			
Maximum layer height (mm):			150			
Minimum format size:	9	32				
Max. format size:	85	180				
<b>Separation knife optionally</b>						
	L	W				
Min. format size:	55	100				
Minimum sheets between separation:	1 sheet					
<b>Counting Technology</b>						
Counting method:	Disc					
Counting direction:	Right to left					
<b>GSM and disc range</b>						
	Min.	Max.	Disc Type	Counting position	Standard for	
GSM (g/m <sup>2</sup> ):	35	70	C1	Corner	Tax stamps	
GSM (g/m <sup>2</sup> ):	35	150	C2	Corner	Banknotes	
Values are subjected to rigidity sensitivity and quality of processed products. During processing of the products values might differ.						
<b>Counting speed</b>						
	RPM	Disc Type	GSM range	Segments	Sheets / min.	Sheets / sec.
Rated RPM:	2000	C1	35 - 70	6	12000	200
Rated RPM:	2000	C2	35 - 150	6	12000	200
Values are subjected to rigidity sensitivity and quality of processed products. During processing of the products values might differ.						
<b>Processable substrates</b>						
Currency Industry	Currency and documents paper, coated or uncoated, polymers and hybrids.					
Consumer Industry	Consumer paper, coated or uncoated, laminated, plastics and polymers					
<b>PLC Control</b>						
Brand:	B&R					
Touchscreen:	5,7" B&R coloured multilingual, main HMI with pictograms					
Interfaces:	FTP (Client / Server)/USB/MQTT (TCP / IP)/OPC UA/Profinet/Profibus/Ethernet-IP/ Device Net / CAN-Bus / CAN-Open / EtherCat / X2X Link Powerlink / Modbus TCP /					
<b>Operating Noise</b>						
Max. db(A) at 3000 RPM:	78					
<b>Environmental conditions</b>						
Rec. temperature range (+°C):	15	35				
Rec. relative humidity range (%):	35	45				
<b>Certification</b>						
CE Certificate:	In conformation to all applicable European standards.					

Machine Layout

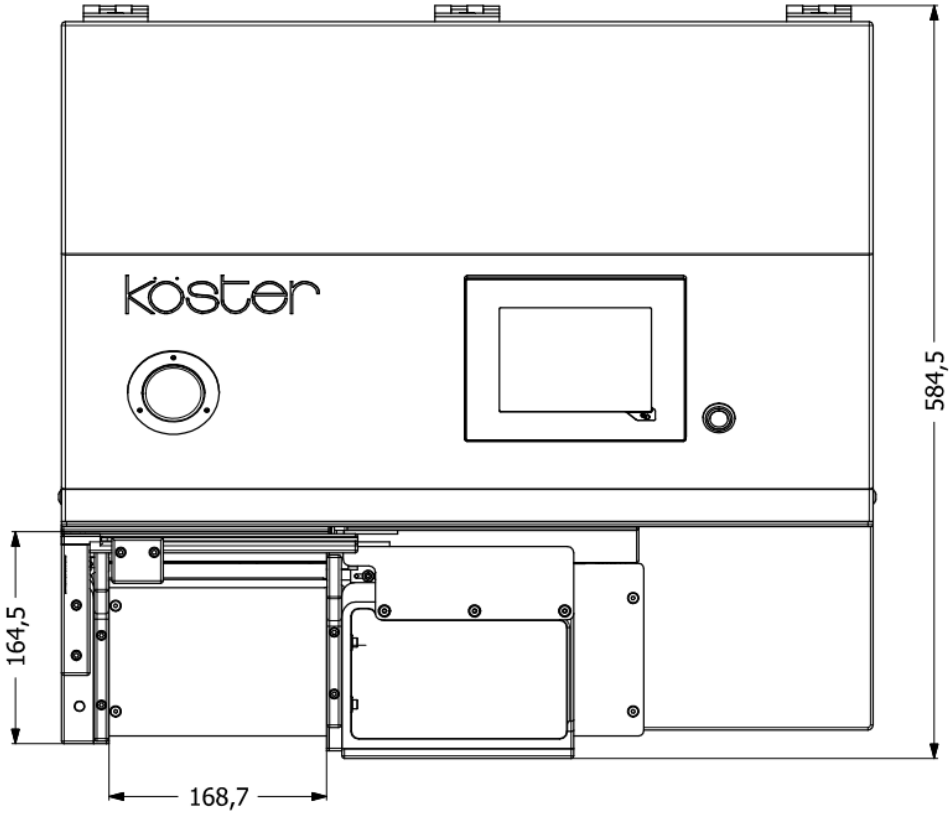
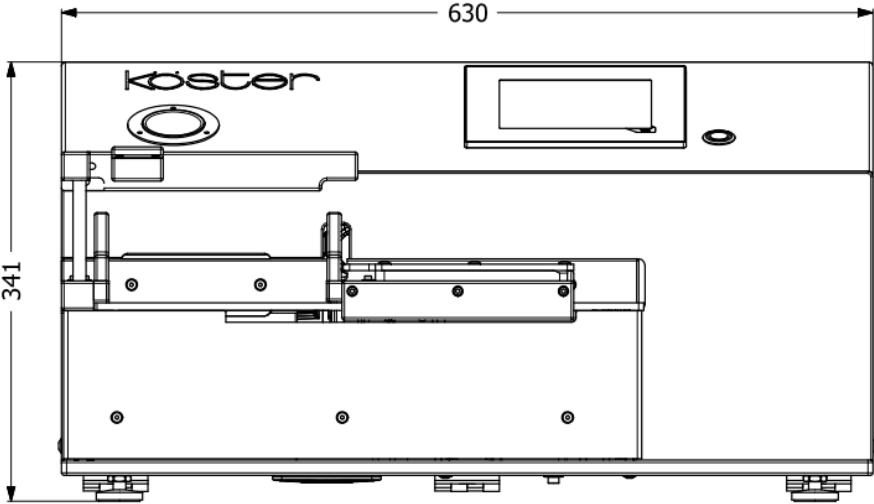

# HPC – HIGH PERFORMANCE COUNTING

## Basic information concerning HPC- Equipment

### Counting Machines:

- Maximum counting speed refers generally to the rated maximum rpm value and the machine design.
- It is not granted that maximum speed can be attended using all kind of substrates / materials.
- Warranty time 12 months upon issuing of the acceptance certificate.
- Warranty extension 24 months optionally available.
- Warranty coverage except wear parts.

### Counting Discs:

- The details of the GSM values are based on experience and tests. Depending on the product rigidity, these values may differ.
- Older produced counting discs for corner position are designated by 1xx,x for the diameter in "mm" and / or "V8 - V15" depending on the type.
- Newly produced counting discs for corner position are designated by "C1-Cx" depending on the type.
- Newly produced counting discs for edge position are designated by "S1-Sx" depending on the type.
- Warranty for the lifetime of the counting discs is not granted as the abrasive wear depends highly to the processed product.

**Köster**  
Maschinen- und Werkzeugbau

Köster GmbH · Maschinen- und Werkzeugbau · Robert-Bosch-Straße 4 · D-74182 Obersulm-Willsbach  
Telefon: +49(0) 7134 4051 · E-Mail: [service@koester-gmbh.de](mailto:service@koester-gmbh.de) · Internet: [www.koester-gmbh.de](http://www.koester-gmbh.de)